



Facilities Study For Southwest Power Pool (SPP)

ERAS 2025-001

Group 5

ERAS-2025-027

Xcel Energy Services, Inc.

Southwestern Public Service Co.

Transmission Planning South

Updated 5/7/2026

Executive Summary

The Southwest Power Pool (SPP or Transmission Provider [TP]) evaluated the generation facilities requesting to interconnect to the SPS transmission system in the Expedited Resource Adequacy Study (ERAS-2025-001), which was completed in February, 2026. The requests for interconnection were placed with SPP in accordance with the Scope of Interconnection Facilities Study GIP Section 8.10 and the Interconnection Facilities Study Procedures in accordance with GIP Section 8.11.

ERAS-2025-027 (Interconnection Customer or IC) requested the interconnection of a 250 MW battery storage (BESS) energy generation facility, located in Yoakum County, Texas, to the Southwestern Public Service Company (SPS or Transmission Owner [TO]) transmission network. To accommodate the Interconnection Customer's (IC) request(s), SPS will expand the 230 kV substation named Mahoney. The substation will be laid out as a five-breaker ring bus and be expandable for future breaker and one-half configuration. After substation construction is complete, the IC will connect to the SPS 230 kV bus. The IC is required to build one 230 kV generation tie-line from their collector substation facilities to the SPS Substation. The IC will be required to maintain a Power Factor between 0.95 lagging and 0.95 leading at the POI.

The customer will refer to other requirements that may be needed at the following link: [Salesforce \(Xcel Energy Interconnection Guidelines For Transmission Interconnected Producer-Owned Generation Greater Than 20 MW\)](#).

Coordination with Xcel Energy is required during the under-frequency relay-setting phase for the generation. The IC is required to report their generation off-nominal frequency tripping relay settings to SPP and SPS. SPS specifies that generators shall not trip at frequencies above 58.5 Hz unless exceptions in the Transmission Provider Criteria are met. The IC agrees that the energy generating units installed at this interconnection will not be tripped for under-frequency conditions above 58.5 Hz in compliance with Transmission Provider criteria. This means that the generation subject to this Interconnection Agreement may not trip for under-frequency conditions on the transmission system until all under-frequency load shedding relays have operated. SPS will also require that the IC follow all applicable criteria, guidelines, standards, requirements, regulations, and procedures issued by the North American Electric Reliability Corporation (NERC), SPP, and the Federal Energy Regulatory Commission (FERC) or their successor organizations.

The IC is responsible for all the cost of the Interconnection Facilities, installation of the direct assigned Transmission Owner Interconnection Facilities (TOIF) which are facilities paid for by the IC but are owned, operated, and maintained by SPS; inclusive of all construction required for the IC to interconnect at SPS' Substation.

Other network upgrades identified by SPP will impact on the total overall costs for interconnection of the IC.

It is anticipated that the entire process of constructing the Substation for the acceptance of the IC facility output and the network upgrades allocated to this project will require approximately 36-42 months to complete after an Interconnection Agreement is signed and authorization to proceed is received. The IC's cost for the interconnection of this generation facility is shown below in Table 1:

Table 1: Cost Summary¹

Non-shared Network Upgrades:	\$ 14,182,594
Transmission Owner Interconnection Facilities:	\$ 4,947,579

¹ The cost estimates are 2026 dollars with an accuracy level of ±20%.

Total:	\$ 19,130,173
--------	---------------

General Description of SPS² Facilities

1. **Construction at the SPS Mahoney Substation:** See Appendix A, Figure A-1 for general vicinity location map of the SPS facility.

Location: The IC will build one 230 kV generation tie-line from their generation facility to the 230 kV Mahoney Substation, in Yoakum County, Texas. SPS requires the IC to run dual OPGW conductors from their generation facility to provide redundant communication. The customer will terminate their generation tie-line to transmission terminal structures installed and owned by SPS. The transmission terminal structures will be located outside of the Substation. SPS will install transmission jumpers at the transmission terminal structure and phase conductors along with fiber optics cable to the Point-Of-Interconnection terminal inside the Substation. The transmission terminal structure will provide a clear change-of-ownership point for the IC.

Bus Design: The 230 kV, ring-bus configuration, expandable to a breaker and one-half configuration will be constructed to accommodate the POI for the ERAS-2025-027 battery storage generation facility.

Revenue Metering: An individual billing meter will be installed at the SPS substation on the line terminal from the IC's substation, which meets the standards: ANSI C12.1 accuracy class 0.2 (3-PT's IEEE C57.13 accuracy class 0.3 and 3-CT's IEEE C57.13 accuracy class 0.15) for full 3-phase 4-wire metering. Pulses out of the billing meter will be sent via SCADA to the Transmission Owner's Control Center in Amarillo, Texas.

Disturbance Monitoring Device: A Disturbance Fault Recorder (DFR), capable of recording faults, swings, and long-term trending, will be installed to monitor and record conditions in the substation and on the transmission lines. The disturbance equipment will also be equipped with a GPS time synchronizing clock. This equipment will have communication capability with a dedicated communication circuit. The disturbance equipment will have its own dedicated communications circuit.

Remote Terminal Unit (RTU): An RTU will be utilized for communications with the new IC facilities. A Communication SEL Relay will be utilized for relay communications and other functions as required; these costs will be directly assigned to the IC. The IC will provide and install a RTU for metering and telemetry at the IC's facility as required by the latest Xcel Energy Interconnection Guidelines.

Communications: To meet its Communications obligations, the IC shall be responsible for planning with the local phone company to provide a communication circuit as required by the Transmission Owner. Transmission Owner equipment may include but is not limited to the following: relay communication equipment, RTU, and disturbance monitoring equipment. Prior to any construction, the IC is required to contact the Transmission Owner substation-engineering department for all communication details and provide detail of the method to be used in communication.

The following communications schematic diagram, which includes communication equipment information for the IC, Transmission Provider (Southwest Power Pool) and Transmission Owner (Southwestern Public Service), is provided to assist the Parties as a template:

² All modifications to SPS facilities will be owned, maintained, and operated by SPS.

A schematic outlining the proposed communications is provided below:

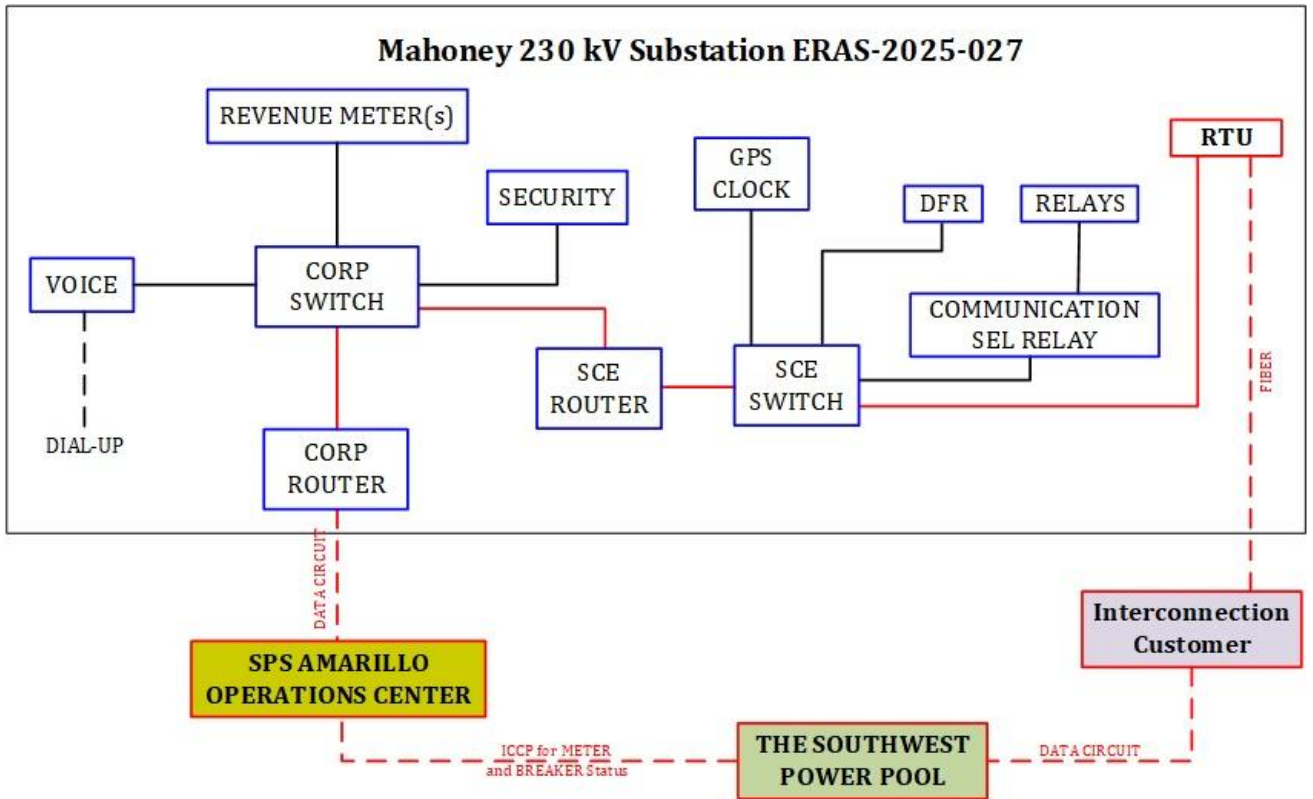

The IC shall be responsible for providing the dual fiber optic communication circuit installed in the overhead transmission line static wire from the customer’s substation to the SPS substation for protective relaying and for transmitting metering and status data to SPS. Utilizing this fiber optic connection, SPS will establish a direct connection to the IC’s RTU.

SPS will not serve as a proxy for communication from the IC to SPP.

2. Transmission and Remote Substation Work – Engineering and Construction

- a. **Coordination:** The Xcel Energy Transmission Engineering and Design groups require an engineering review of the customer’s design prior to any construction by the IC or its contractor on any customer transmission lines, the proposed termination to the SPS substation, or doing work in close proximity to any SPS transmission line. It is the IC’s responsibility to initiate the design review in a timely manner before construction of any transmission line begins. If the review has not been made or the design at any of the aforementioned locations is deemed inadequate, the crossing(s) and or termination into the interchange will be delayed until the matters are resolved. SPS will not be held responsible for these delays
- b. **Fault or Short Circuit Study:** The IC will coordinate with the System Protection Engineering department at SPS on the available fault current at the interconnection location following the acceptance of the Generator Interconnection Agreement (GIA) and prior to final design on the IC’s facilities. The table below shows the approximate available fault current at the interconnection location. The fault data does not contain fault current contribution from the IC’s facility.

Table 1: Available fault current at interconnection location

Short Circuit Information without contribution from new Generator Facilities (ERAS-2025-027)				
Fault Location	Fault Current (Amps)		Impedance (Ω)	
	Line-to-Ground	3-Phase	Z^+	Z^0
Mahoney Substation	4835.56	14641.6	0.83910, j9.03049	1.69413, j9.20055

3. Right-Of-Way

- a. **Permitting:** The IC will be responsible for any permitting and right of way of their substation and their generation tie-line from their collector substation to the Mahoney Substation. The customer will refer to the Xcel Energy *Right-of-Way, Easements, and Encroachments* web page and the attached Xcel Energy Job Aid document for information concerning crossing of SPS transmission lines with customer generation tie-lines: [Right of Way | Transmission | Corporate | Xcel Energy](#)

4. Construction Power and Retail Service

- a. **Responsibility:** It is the sole responsibility of the IC to arrange for both construction and station power. The IC needs to plan for retail service from the local retail provider. The retail provider and the Customer will be responsible for making any necessary transmission service arrangements as required under the SPP OATT.

5. Project and Operating Concerns:

- a. **Collaboration:** Close work between the Transmission group, the IC’s personnel and local operating groups will be imperative in order to meet any in-service date that has been established.
- b. **Reactive Power Requirements:** The IC will be required to maintain a power factor between 0.95 lagging and 0.95 leading at the Point of Interconnection (POI). All capacitors required will be installed on the lower voltage bus at IC’s substation. This is required to maintain acceptable dynamic voltage rise as per latest revision of the Xcel Energy Interconnection Guidelines for Transmission Interconnection Producer-Owned Generation Greater than 20 MW. If switched reactive devices are used on the IC’s system, they need to be switched in stages where the voltage rise is less than 3%.

6. Estimated Construction Costs and Schedule

- a. **Schedule:** An engineering and construction schedule for this project is estimated at approximately 36 - 42 months. Other factors associated with clearances, equipment delays, and work schedules could cause additional delays. This is applicable after all required agreements are signed and internal approvals are granted.
- b. All additional costs for work not identified in this study are the sole responsibility of the IC unless other arrangements are made.

Appendix A

Figure A-1: General vicinity location map of the POI Substation

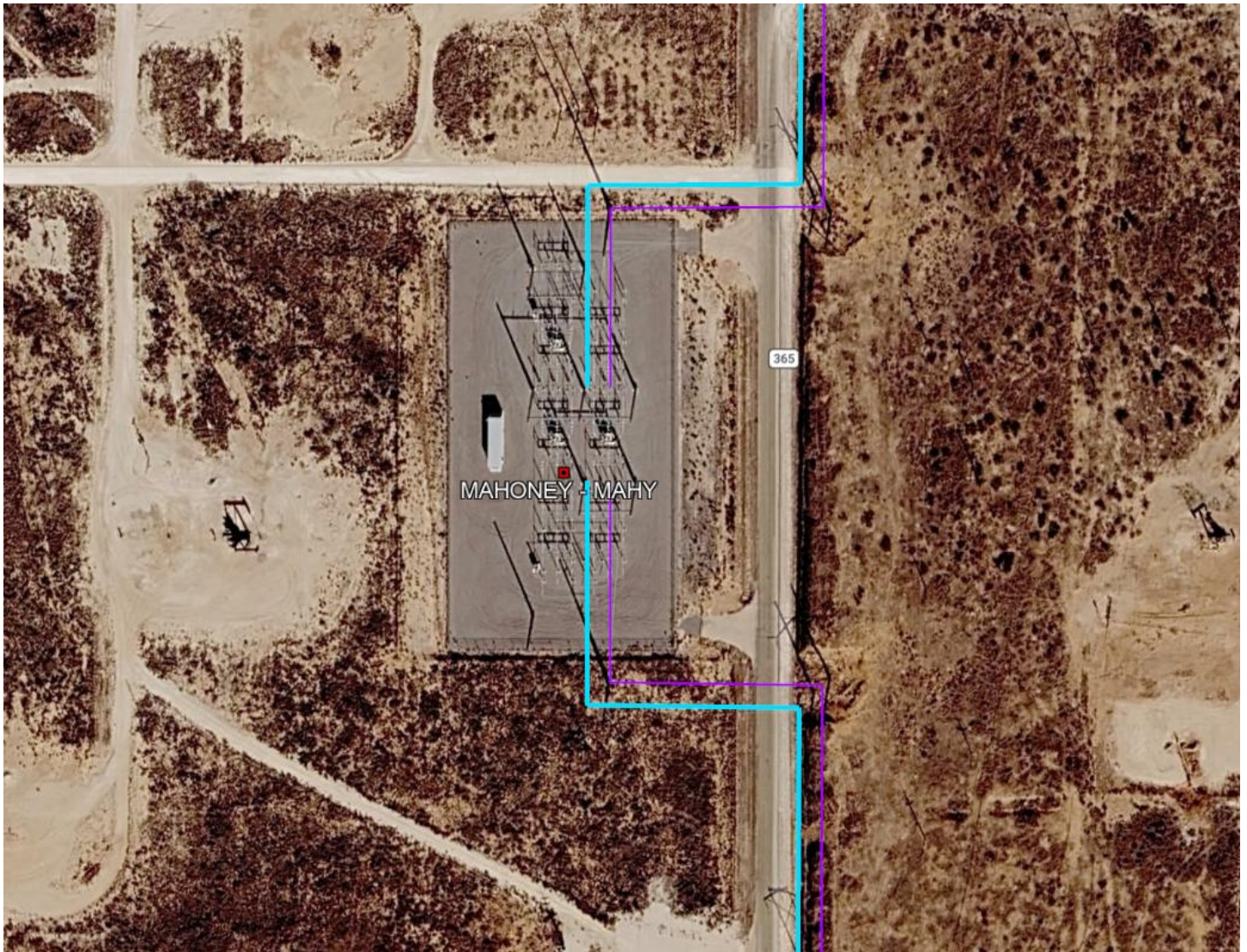

Mahoney POI Substation 2365 CR 365 Denver City, Texas 79323

33.042041 N, -102.733209 W

Figure A-2: Transmission Terminal Structure & Change of Ownership

DIAGRAMS ARE NOT FOR CONSTRUCTION PURPOSES

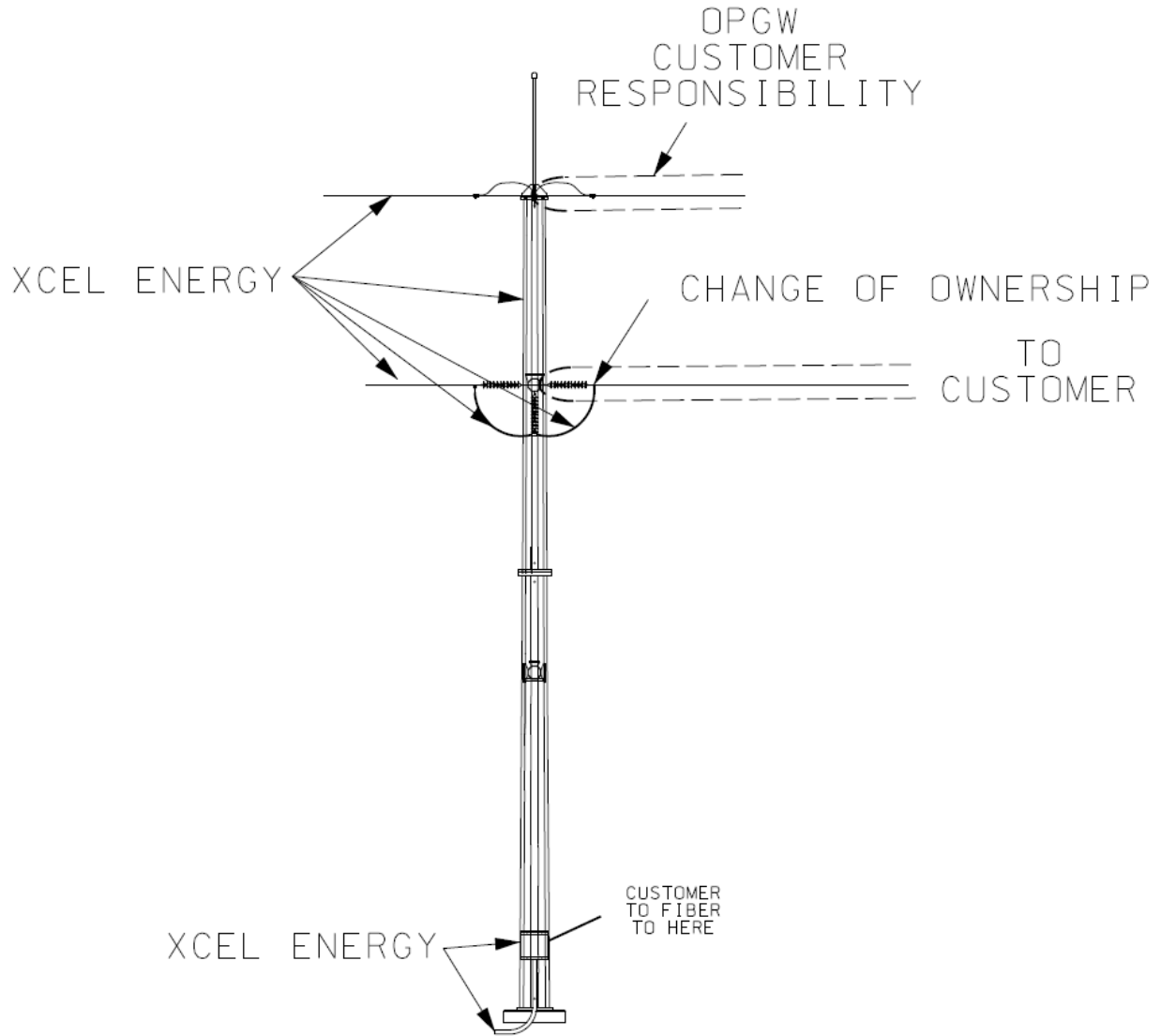
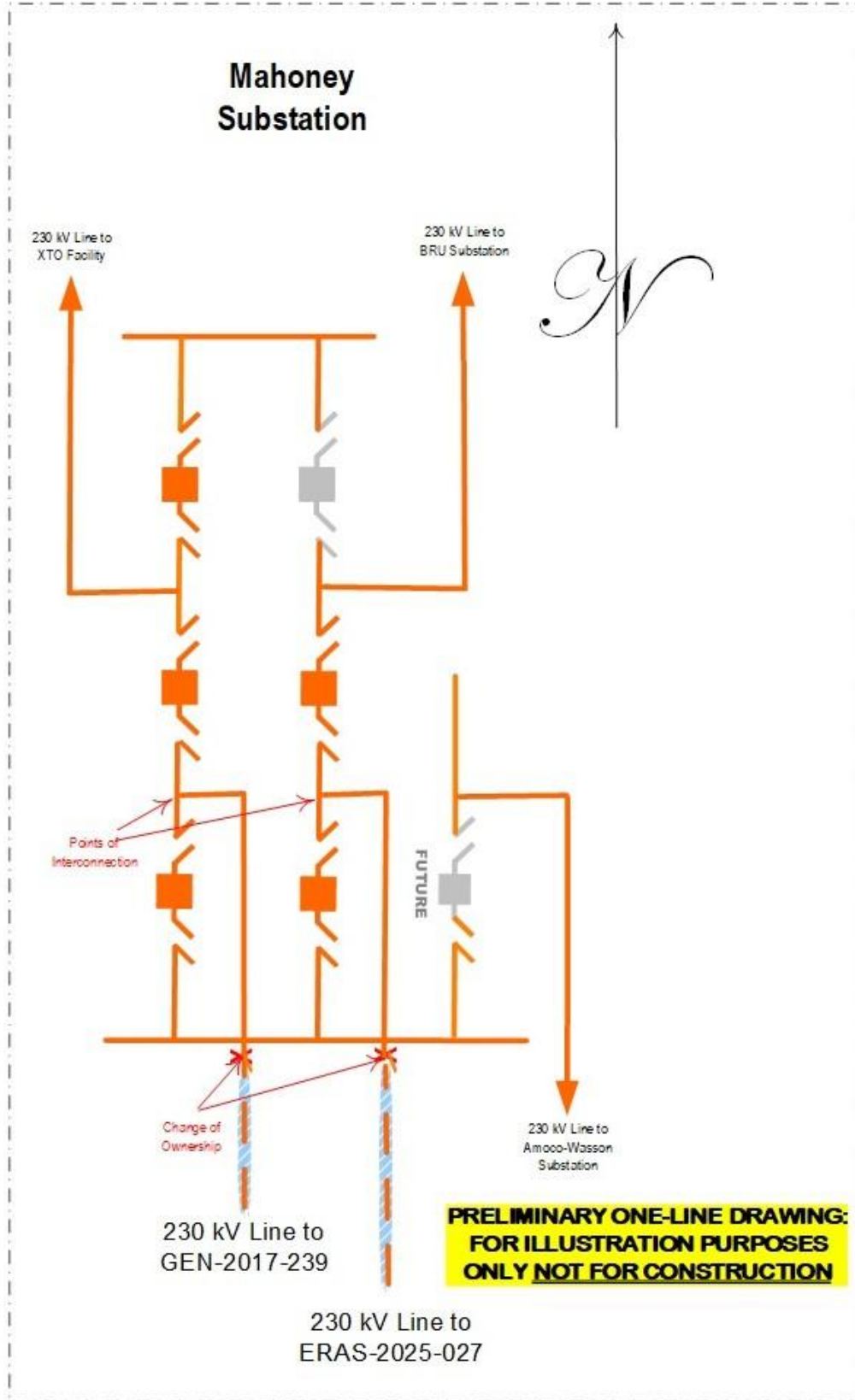

Figure A-3: Preliminary One-Line Diagram

DIAGRAMS ARE NOT FOR CONSTRUCTION PURPOSES



– END OF REPORT –



**Facility Study for Network Upgrades
as Requested by Southwest Power Pool (SPP)**

ERAS-2025
Group 5

Southwestern Public Service CO.
Transmission Planning
Updated 5/8/2026

Executive Summary

The Southwest Power Pool (SPP or Transmission Provider) evaluated the generation facilities requesting to interconnect to the SPS transmission system in the Expediated Resource Adequacy Study (ERAS-2025), which was completed in February 2026. The requests for interconnection were placed with SPP in accordance with the Scope of Interconnection Facilities Study GIP Section 8.10 and the Interconnection Facilities Study Procedures in accordance with GIP Section 8.11.

To accommodate the Interconnection Customer's (IC) requests, SPP identified multiple network upgrades required as part of the ERAS-2025 study results. Southwestern Public Service Company (SPS or Transmission Owner) performed this Facility Study for the Network Upgrades. Below are the projects identified by SPP:

<u>ERAS-2025 Upgrade Name</u>	<u>SCERT UID</u>	<u>Estimate</u>
Replace Tolk 345/230 kV Transformer #1 to minimum of 748 MVA	172065	25,186,202.00
Upgrade R12 (Mahoney-Amoco Wasson) Terminal Equipment at Amoco Wasson to minimum SN/SE 498/547.8 MVA	172043	318,721.00
Upgrade K55 (Mustang-Amoco Wasson) Terminal Equipment at Amoco Wasson to minimum SN/SE 498/547.8 MVA	172042	511,920.00
Rebuild K79 (Yoakum-BRU) to minimum 665 MVA SE	172066	9,319,312.00
Rebuild K56 (Yoakum-Mustang) to minimum 620 MVA SE	172067	18,475,361.00
Rebuild R11 (BRU-Mahoney) to minimum 680 MVA SE	172044	4,497,794.00

General Description of Network Upgrades

The Objective of this study is to identify the network upgrades and the costs associated with them. Below is a description of the different projects and the scoping level costs¹ associated with each. All costs identified below are without escalation. All projects, routes, and costs are subject to change.

Replace Tolk 345/230 kV Circuit 1 Transformer To A Minimum Rating 748 MVA

The existing transformer No. 1 is rated at 500 MVA. The existing tertiary winding is rated at 13.2 kV. The new transformer will be rated at 784 MVA, which is a standard size for SPS 345/230 kV transformers. The new tertiary winding will be rated at 34.5 kV

Substation Details

Apart from the usual removal of existing equipment, relocation of equipment, expansion of the transformer grounding grid, new trenching, etc. A lot of the work for this project is devoted to new removal of the existing 13.2 kV rated equipment and appurtenances associated with it and replacing with new equipment rated for 34.5 kV.

Total Cost

The total cost estimate for this Network Upgrade is:

\$ 25,186,202.00

The estimate is accurate to +/- 20%.

Time Estimate

From date of execution of agreement to project in-service date.

Total Project Duration	42	Months
------------------------	----	--------

Figure 1 - Tolk 345/230 kV Circuit 1 Transformer

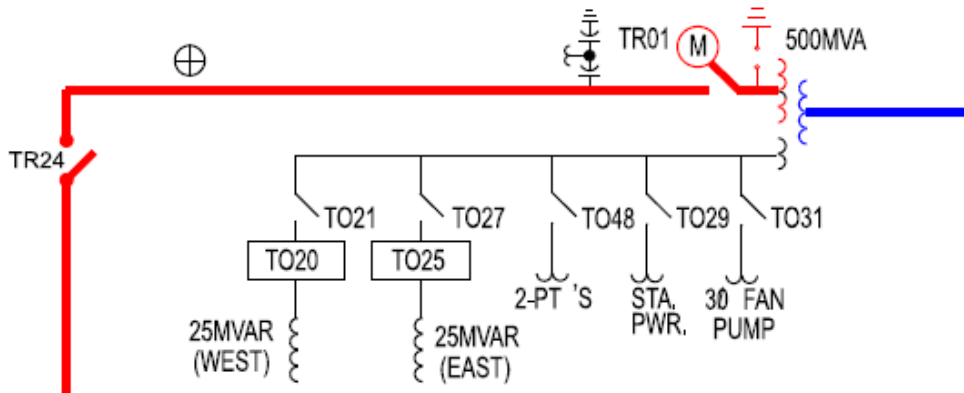

¹ The cost estimates are 2026 dollars with an accuracy level of ±20%.

Upgrade R12 (Mahoney – Amoco Wasson) Terminal Elements at Amoco Wasson to Achieve a Minimum SN/SE rating of 498/547.8 MVA.

Replace all the terminal elements that are below the requested rating. Upgrades will remove the limiting elements that are reducing the capacity of the line.

Substation Details

The majority of the work consists of replacing several 795 ACSR (Drake) jumpers with (2) 1590 “Coreopsis” AAC conductors.

Total Cost

The total cost estimate for this Network Upgrade is:

\$ 318,721.00

The estimate is accurate to +/- 20%.

Time Estimate

From date of execution of agreement to project in-service date.

Total Project Duration	24-36	Months
------------------------	-------	--------

R12 (Mahoney – Amoco Wasson) Terminal Upgrades

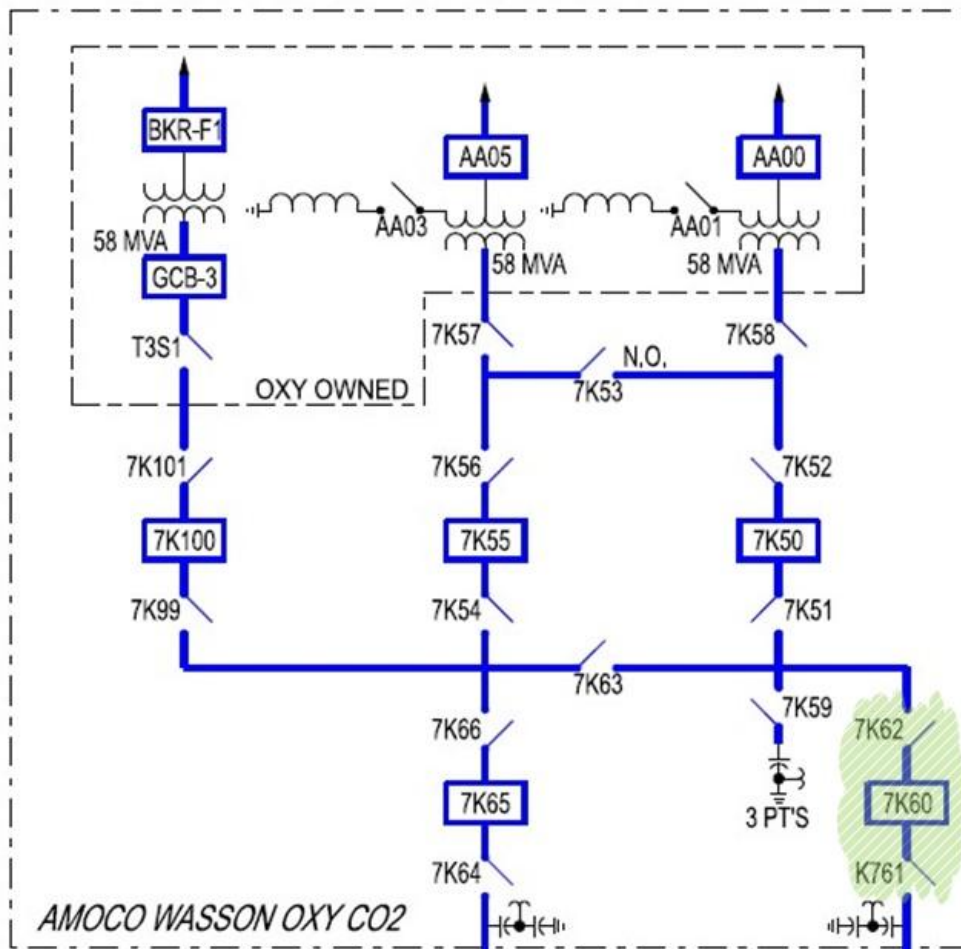

Upgrade K55 (Mustang – Amoco Wasson) Terminal Elements at Amoco Wasson to Achieve a Minimum SN/SE rating of 498/547.8 MVA.

Replace all the terminal elements that are below the requested rating. Upgrades will remove the limiting elements that are reducing the capacity of the line.

Substation Details

The majority of the work consists of replacing several 795 ACSR (Drake) jumpers with (2) 1590 “Coreopsis” AAC conductors.

Total Cost

The total cost estimate for this Network Upgrade is:

\$ 511,920.00

The estimate is accurate to +/- 20%.

Time Estimate

From date of execution of agreement to project in-service date.

Total Project Duration	24-36	Months
------------------------	-------	--------

K55 (Mustang – Amoco Wasson) Terminal Upgrades

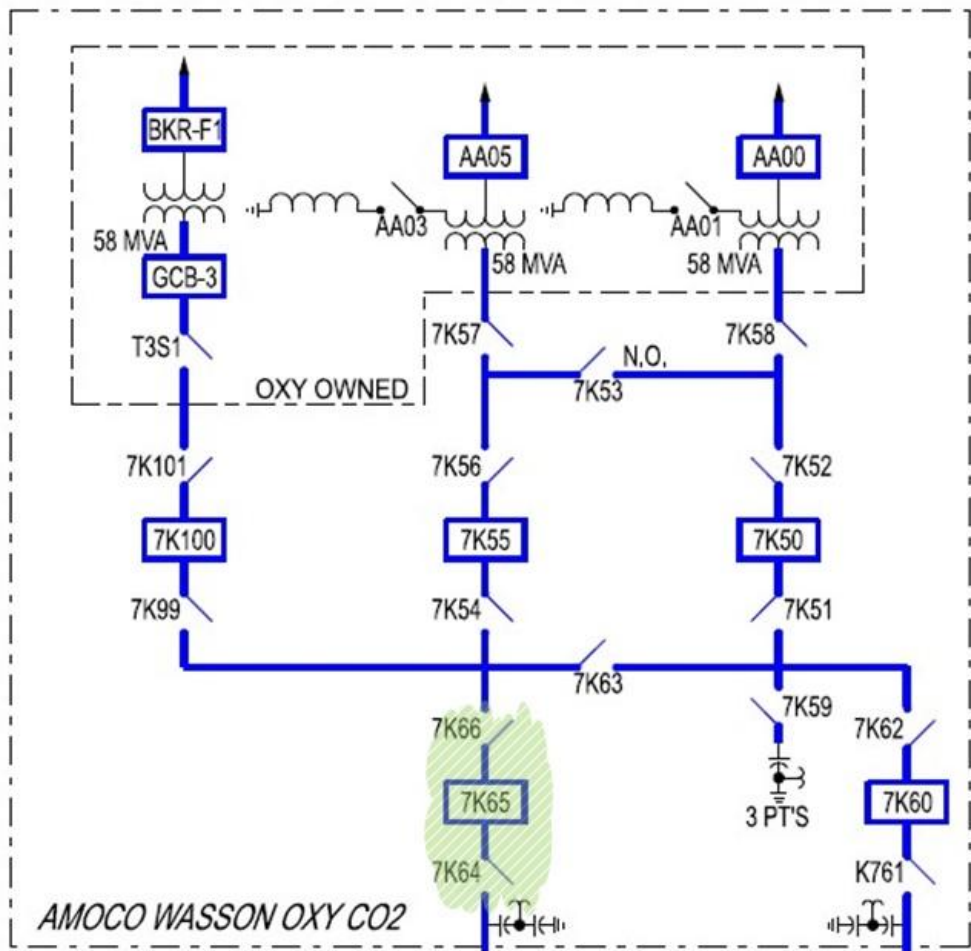

Rebuild K79 (Yoakum – BRU) 230 kV Transmission Line to Achieve a Minimum SE rating of 665 MVA.

The existing line has a SN/SE rating of 470/470 MVA. The new rebuild will vastly improve the capacity of the line. The total line length is 5.51 miles.

Project Details

The line was originally built using wood, H-Frame structures and 795 “Drake” ACSR phase conductors. A segment of the line (2.1 miles) is double-circuit with the 115 kV line V66 (Yoakum – Seagraves). The line will be rebuilt using weathered-steel H-Frames structures for the double-circuit portion and weathered-steel monopoles for the single-circuit portion. The new phase conductors will be 795 “Drake” ACSS conductors. Terminal upgrades at Yoakum County and BRU substations include replacing 795 “Drake” ACSR line terminal jumpers with (2) 1590 “Coreopsis” AAC conductors.

Total Cost

The total cost estimate for this Network Upgrade is:

\$ 9,319,312.00

The estimate is accurate to +/- 20%.

Time Estimate

From date of execution of agreement to project in-service date.

Total Project Duration	40	Months
------------------------	----	--------

K79 (Yoakum Co. – BRU) Line Rebuild



Rebuild K56 (Yoakum – Mustang) 230 kV Transmission Line to Achieve a Minimum SE rating of 620 MVA.

The existing line has a SN/SE rating of 447/447 MVA. The new rebuild will vastly improve the capacity of the line. The total line length is 13.86 miles.

Transmission Details

The line was originally built using wood, H-Frame structures and 795 “Drake” ACSR phase conductors. A short segment of the line (0.9 miles) is double-circuit with the 115 kV line V49 (Yoakum – Shell CO₂). The line will be rebuilt using weathered-steel monopoles. The new phase conductors will be 795 “Drake” ACSS conductors. Terminal upgrades at Yoakum County and Mustang substations include replacing 795 “Drake” ACSR and 954 “Cardinal” line terminal jumpers with (2) 1590 “Coreopsis” AAC conductors.

Total Cost

The total cost estimate for this Network Upgrade is:

\$ 18,475,361.00

The estimate is accurate to +/- 20%.

Time Estimate

From date of execution of agreement to project in-service date.

Total Project Duration	40	Months
------------------------	----	--------

K56 (Yoakum Co. – Mustang) Line Rebuild

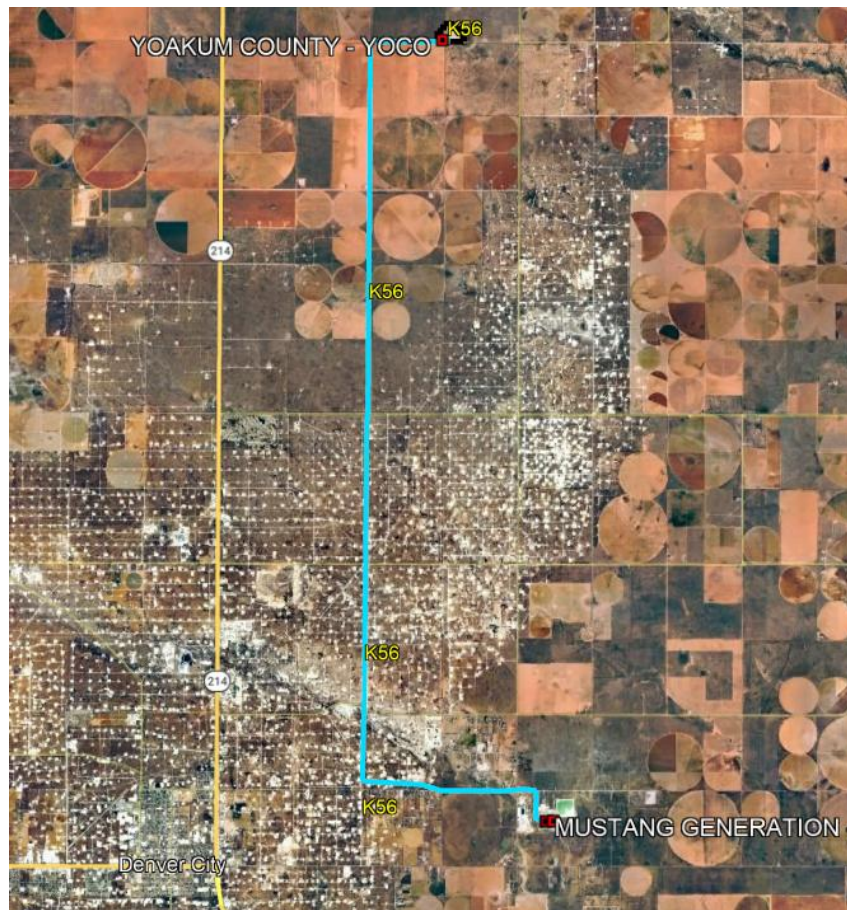

Rebuild R11 (Mahoney - BRU) 230 kV Transmission Line to Achieve a Minimum SE rating of 680 MVA.

The existing line has a SN/SE rating of 399/399 MVA. The new rebuild will vastly improve the capacity of the line. The total line length is 2.68 miles.

Transmission Details

The line was originally built using wood, H-Frame structures and 795 “Drake” ACSR phase conductors. The line will be rebuilt using weathered-steel monopoles. The new phase conductors will be 795 “Drake” ACSS conductors. Terminal upgrades at BRU substation include replacing 795 “Drake” ACSR and 4/0 “Penguin” line terminal jumpers with (2) 1590 “Coreopsis” AAC conductors.

Total Cost

The total cost estimate for this Network Upgrade is:

\$ 4,497,794.00

The estimate is accurate to +/- 20%.

Time Estimate

From date of execution of agreement to project in-service date.

Total Project Duration	40	Months
------------------------	----	--------

R11 (Mahoney - BRU) Line Rebuild



– END OF REPORT –



AEP Generation Interconnection

Facilities Study Report

for

ERAS-2025-001

Lawton Eastside to Oklaunion 345 kV Line

Rebuild

Southwest, Oklahoma

April 2026

1 Facilities Study Summary

American Electric Power (AEP) Southwest Transmission Planning performed the following study at the request of the Southwest Power Pool (SPP) for SPP Generation Interconnection request ERAS-2025-001. Per the SPP Generator Interconnection Procedures (GIP), SPP requested that AEP perform an Interconnection Facilities Study (IFS) for Network Upgrade(s) in accordance with Attachment V, Section 8.11 of the Generator Interconnection Procedures (GIP).

Lawton Eastside to Oklaunion 345 kV

- Rebuild the approx. 66.8-mile line to achieve the desired 1080/1390 MVA summer normal/emergency rating.

1.1 Project Description

Per the ERAS-2025-001 study request, AEP proposes to rebuild the Lawton Eastside to Oklaunion 345 kV line (Figure 1) in southwest, Oklahoma.

1.2 AEP's Scope of Work to Facilitate Interconnection

- To accommodate the desired summer normal/emergency rating of 1080/1390 MVA requested for the Lawton Eastside to Oklaunion 345 kV line, the approx. 66.8-mile line will be rebuilt.
- The design and construction of the new equipment will meet all AEP specifications for transmission lines. AEP will own, operate, and maintain the Lawton Eastside to Oklaunion 345 kV line.
- It is understood that the Interconnection Customers are responsible for the cost of all of this work.

1.3 Short Circuit Evaluation

- It is standard practice for AEP to recommend replacing a circuit breaker when the current through the breaker for a fault exceeds 100% of its interrupting rating with recloser de-rating applied, as determined by the ANSI/IEEE C37.5-1979, C37.010-1979 & C37.04-1979 breaker rating methods.
- In the AEP system, no breakers were found to exceed their interrupting capability after the addition of this equipment. Therefore, there are no additional short circuit upgrade costs associated with the ERAS-2025-001, UIDs 172047 & 172048.

1.4 Interconnection Cost of Facilities Included in the Facilities Study:

Rebuild the ~4.3-mile line from the Lawton Eastside to Comanche Tap 345 kV	\$18,952,333
Rebuild the ~62.5-mile line from the Oklaunion to Comanche Tap 345 kV	\$285,578,735
Total Cost	\$304,531,068

The estimates do not include the impact that delays in obtaining ROW, permits, or other approvals may have.

1.5 Project Lead time

Project in-service date is projected to be 48 months after the issuance of Authorization to Proceed from the Interconnection Customer.

Figure 1

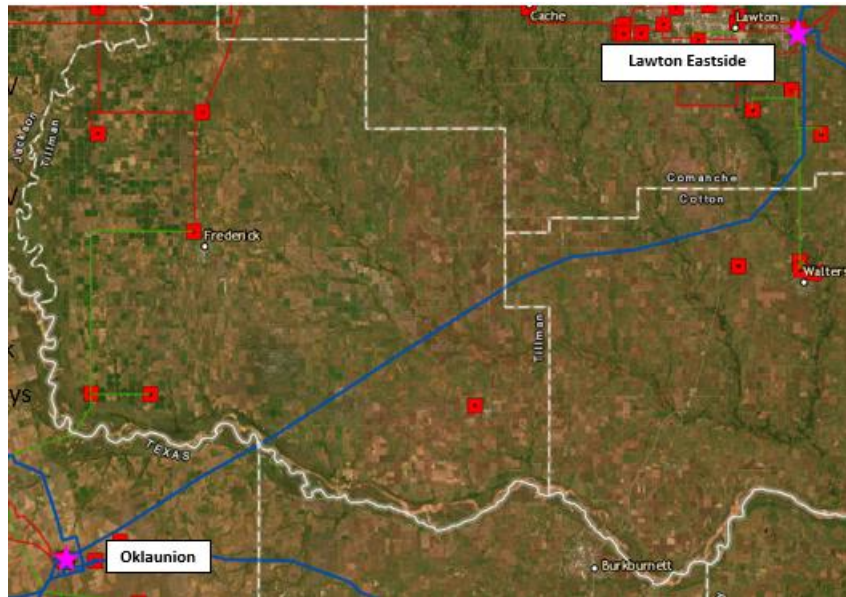



AEP Generation Interconnection

Facilities Study Report

for

ERAS-2025-001

Elk City 230/138 kV Transformer Upgrades

Beckham County, Oklahoma

April 2026

1 Facilities Study Summary

American Electric Power (AEP) Southwest Transmission Planning performed the following study at the request of the Southwest Power Pool (SPP) for SPP Generation Interconnection request ERAS-2025-001. Per the SPP Generator Interconnection Procedures (GIP), SPP requested that AEP perform an Interconnection Facilities Study (IFS) for Network Upgrade(s) in accordance with Attachment V, Section 8.11 of the Generator Interconnection Procedures (GIP).

Elk City 230/138 kV Transformer

- Upgrade equipment associated with the Elk City 230/138 kV auto to achieve a desired 295/450 MVA summer normal/emergency rating.

1.1 Project Description

Per the ERAS-2025-001 study request, AEP proposes to upgrade equipment associated with the Elk City 230/138 kV auto (Figure 1) in Beckham County, Oklahoma.

1.2 AEP's Scope of Work to Facilitate Interconnection

- To accommodate the desired summer normal/emergency rating of 295/450 MVA requested for the Elk City 230/138 kV auto, equipment associated with the existing 230/138 kV auto will be upgraded.
- The design and construction of the new equipment will meet all AEP specifications for transmission stations. AEP will own, operate, and maintain the Elk City 230/138 kV auto and associated equipment.
- It is understood that the Interconnection Customers are responsible for the cost of all of this work.

1.3 Short Circuit Evaluation

- It is standard practice for AEP to recommend replacing a circuit breaker when the current through the breaker for a fault exceeds 100% of its interrupting rating with recloser de-rating applied, as determined by the ANSI/IEEE C37.5-1979, C37.010-1979 & C37.04-1979 breaker rating methods.
- In the AEP system, no breakers were found to exceed their interrupting capability after the addition of this equipment. Therefore, there are no additional short circuit upgrade costs associated with the ERAS-2025-001, UID 172056.

1.4 Interconnection Cost of Facilities Included in the Facilities Study:

Upgrade Equipment Associated with the Elk City 230/138 kV Auto	\$1,033,518
Total Cost	\$1,033,518

The estimates do not include the impact that delays in obtaining ROW, permits, or other approvals may have.

1.5 Project Lead time

Project in-service date is projected to be 24 months after the issuance of Authorization to Proceed from the Interconnection Customer.

Figure 1





AEP Generation Interconnection

Facilities Study Report

for

ERAS-2025-001

Elk City to Chisholm 230 kV Line Rebuild

Beckham County, Oklahoma

April 2026

1 Facilities Study Summary

American Electric Power (AEP) Southwest Transmission Planning performed the following study at the request of the Southwest Power Pool (SPP) for SPP Generation Interconnection request ERAS-2025-001. Per the SPP Generator Interconnection Procedures (GIP), SPP requested that AEP perform an Interconnection Facilities Study (IFS) for Network Upgrade(s) in accordance with Attachment V, Section 8.11 of the Generator Interconnection Procedures (GIP).

Elk City to Chisholm 230 kV

- Rebuild the approx. 18.4-mile line to achieve the desired 480 MVA summer emergency rating.

1.1 Project Description

Per the ERAS-2025-001 study request, AEP proposes to rebuild the Elk City to Chisholm 230 kV line (Figure 1) in Beckham County, Oklahoma.

1.2 AEP's Scope of Work to Facilitate Interconnection

- To accommodate the desired summer emergency rating of 480 MVA requested for the Elk City to Chisholm 230 kV line, an existing approx. 18.4-mile line will be rebuilt.
- The design and construction of the new equipment will meet all AEP specifications for transmission lines. AEP will own, operate, and maintain the Elk City to Chisholm 230 kV line.
- It is understood that the Interconnection Customers are responsible for the cost of all of this work.

1.3 Short Circuit Evaluation

- It is standard practice for AEP to recommend replacing a circuit breaker when the current through the breaker for a fault exceeds 100% of its interrupting rating with recloser de-rating applied, as determined by the ANSI/IEEE C37.5-1979, C37.010-1979 & C37.04-1979 breaker rating methods.
- In the AEP system, no breakers were found to exceed their interrupting capability after the addition of this equipment. Therefore, there are no additional short circuit upgrade costs associated with the ERAS-2025-001, UID 172057.

1.4 Interconnection Cost of Facilities Included in the Facilities Study:

Rebuild the approx. 18.4-mile Elk City to Chisholm 230 kV line	\$43,551,586
Total Cost	\$43,551,586

The estimates do not include the impact that delays in obtaining ROW, permits, or other approvals may have.

1.5 Project Lead time

Project in-service date is projected to be 48 months after the issuance of Authorization to Proceed from the Interconnection Customer.

Figure 1

